



N252B

Pre-Flight Check



N252BP

Pre-Flight Check

1. COCKPIT

Gear Switch	DOWN
Magneto/Starter	OFF
Master Switch	ON
Flaps	DOWN
Internal/External Lights	CHECK
Fuel Guages	CHECK
Master Switch	OFF
Fuel Selector	RIGHT
Gascolator	PULL 5 seconds
Fuel Selector	LEFT
Gascolator	PULL 5 seconds

2. RIGHT TAILCONE AREA

Static Port	CLEAR
Right Fuselage	Check Skin Condition
Tail Tiedown	REMOVE

3. EMPENNAGE

Elevator/Rudder Attach Points & Control Linkage	CHECK
General Skin Condition	CHECK
Ice, Snow, or Frost	Remove

4. LEFT TAILCONE AREA

Fresh Air Vent (Dorsal Fin)	CLEAR
Static Port	CLEAR
Left Fuselags	Check Skin Condition
Tailcone Access Door	SECURED
Static System Drain	PUSH Plunger up 5 sec.

5. LEFT WING

Skin Condition	Remove all Ice, Snow, or Frost
Flap & Attach Points	CHECK
Aileron & Attach Points	CHECK
Control Linkages	CHECK
Wing Tip & Lights	CHECK
Left Wing Leadin Edge	CHECK
Pitot Tube	CLEAR; Heat Functioning
Stall Switch Vane	CLEAR
Fuel Tank	CHECK; Secure Cap
Tiedown	REMOVE
Tank Vent	CLEAR
Wheel Chock	REMOVE

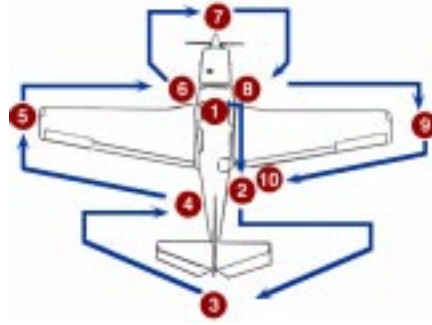

5. LEFT WING

Left Main Gear, Shock discs and Tire	CHECK
Left Main Gear Doors	CHECK
Fuel Tank Sump Drain	DRAIN until Clear
Pitot System Drain	PUSH Plunger UP
Gascolator Drain Valve	CLOSED (Check for drips)

6. LEFT COWL AREA

Windshield	CLEAN
Left Side Engine Cowl Fasteners	SECURED
Cowl Flap	CHECK
Engine Oil	CHECK
Oil Filler Cap	SECURED

7. PROPELLER

Blades	Check for nicks, cracks, & oil leaks
Spinner	Check for security; cracks
Cooling Air Intakes	CLEAR
Landing Light	CHECK
Nose Gear, Shock discs and Tire	CHECK
Nose Gear Door	Check for loose linkage
Wheel Chock	REMOVE

8. RIGHT COWL AREA

Right Side Engine Cowl Fasteners	SECURED
Engine Induction Air Inlet Duct	CLEAR
Exhaust Pipe	SECURED
Windshield	CLEAN

8. RIGHT COWL AREA

Cabin Cooling Vent	CLEAR
--------------------	-------

9. RIGHT WING

Fuel Tank Sump Drain	DRAIN until Clear
Right Main Gear, Shock discs and Tire	CHECK
Right Main Gear Doors	CHECK
Wheel Chock	REMOVE
Tank Vent	CLEAR
Tiedown	REMOVE
Left Wing Leadin Edge	CHECK
Fuel Tank	CHECK; Secure Cap
Wing Tip & Lights	CHECK
Aileron & Attach Points	CHECK
Control Linkages	CHECK
Flap & Attach Points	CHECK
Skin Condition	Remove all Ice, Snow, or Frost

10. BAGGAGE DOOR

Baggage Door	SECURED
--------------	---------